

KIT MASTERS

8500SK Kit Assembly Instructions

DISASSEMBLY

1. Remove clutch from hub by removing the 6 allen bolts. Line the access holes up with the allen bolts to remove the bolts. Apply air pressure to the clutch so the access holes can be aligned with the allen bolts. Once aligned, remove air pressure and the clutch will lock-up.
The clutch will need to be compressed before any removing and installing any parts.
2. To compress the clutch use 2 - 3/8"x3" bolts with a large flat washer over the access holes. Place the bolts opposite of each other and compress the clutch evenly. (see picture) Do not over compress.
3. Remove the Coupling and the O-ring.
4. Remove the Cylinder Cap by removing the 5/16" Locknut, hold the Piston Rod Assembly (on the lining side) with a 5/8" open end wrench to loosen. Under the Cylinder Cap is the Seal Washer. Remove it.
5. Remove the Dust Seal. (If the dust seal is blue, also remove the o-ring underneath it.)
6. Remove the U-Packing Seal. **(Make a note of how the U-Packing Seal was installed, the "U" is facing up as the clutch is placed, lining down).**

INSTALLATION

1. Clean the U-Packing groove and the O-ring groove with a towel and solvent.
2. Apply Lube to the U-Cup Combo Seal and install into the U-Packing groove. **Be sure the "U" is facing up.**
3. Apply extra Lube to the exterior of the Combo Seal after it is in place.
4. Place the Seal Washer, metal side up, over the threads of the Piston Rod Assembly.
5. Place the Cylinder Cap over the Seal Washer and use the 5/16" Locknut to secure.
6. Torque the 5/16" Locknut to 84 Lbs-in (9.5 Newton Meters).
If the Locknut is under tightened, an air leak may occur.
If the Locknut is over tightened the rubber seal may be ineffective and an air leak may occur.
7. Apply Lube to the O-ring and place the O-ring in the groove on the piston rod.
8. Replace the Coupling.
9. Remove the compression bolts.
10. Bolt the clutch to the hub using the 6 bolts provided. Be sure the coupling mates with the Hub.

Patent(s) Pending. See www.kit-masters.com for updated list of applicable issued and pending patents.

For installation assistance, contact Kit Masters at (800)-810-9110

Picture of Compressing the clutch with two 3/8" x 3" bolts



Exploded View and Part Description

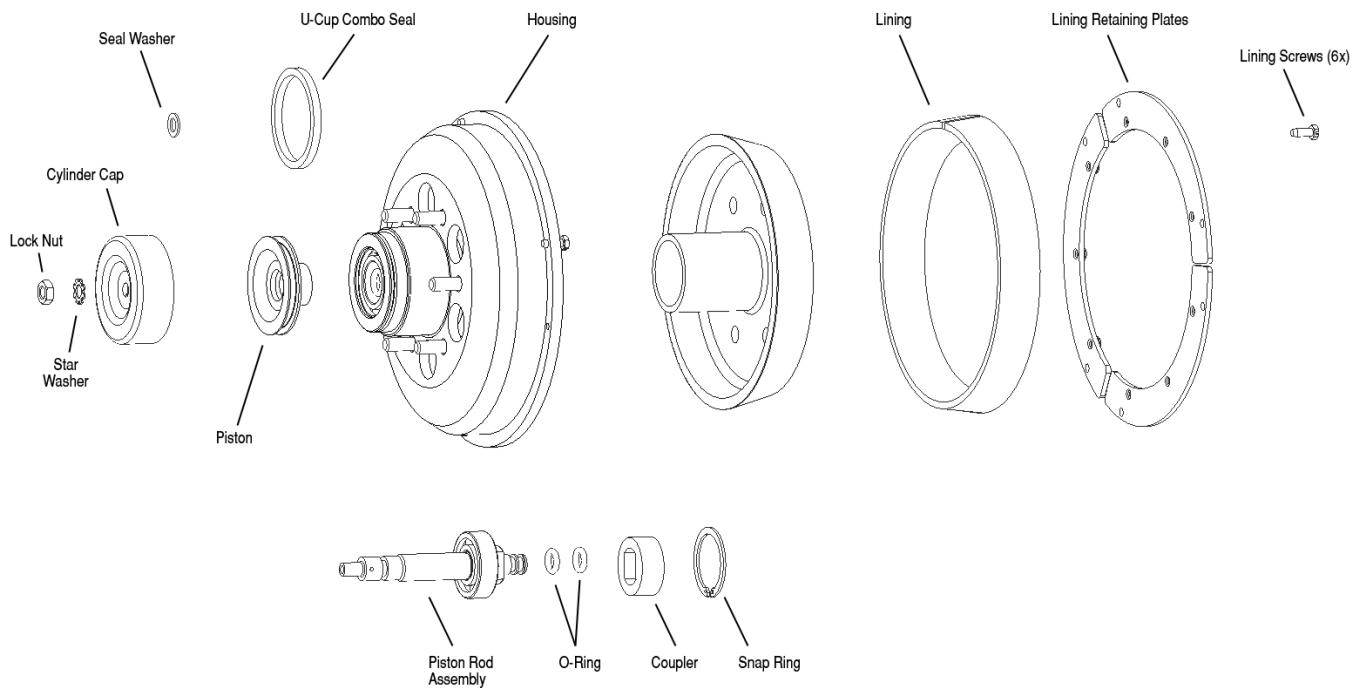

KIT MASTERS

FAN CLUTCH EXPERTS

www.kit-masters.com