

KIT MASTERS

8009N / 8010N / 8011N / 8015N Assembly Instructions

1. Remove old fan clutch
2. a. For 8009N or 8011N - Spacer must be installed between pulley and fan clutch (see image below)
b. For 8010N or 8015N - Add hex head spacer between pulley and fan clutch (see image below)
3. Bolt new fan clutch to pulley. Torque to 45 ft-lbs.

**This fan clutch requires air to disengage, so reversing the solenoid is required.
If solenoid is not reversible, you must purchase Part #3282.**

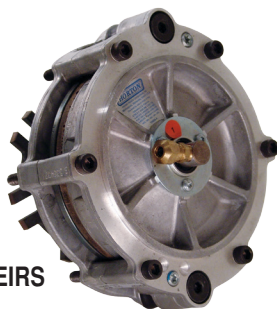
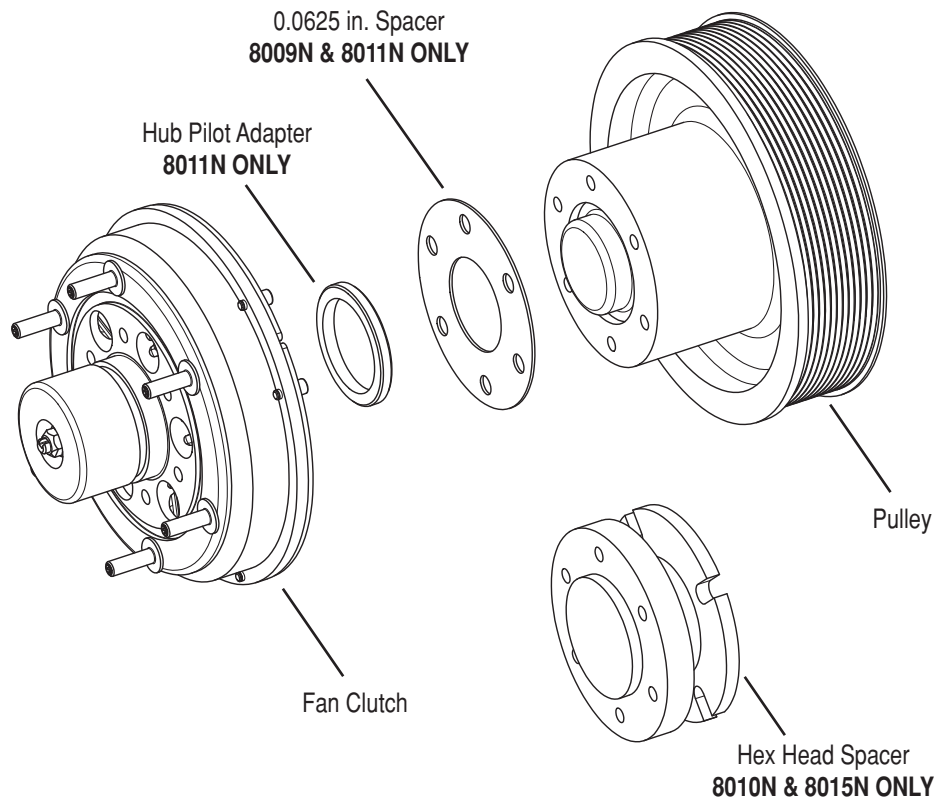

**It looks different,
because it IS different.**

This is a direct replacement/upgrade for HT650® / HT550® fan clutches. The superior design of the 8009N makes for easier and more affordable long-term maintenance. Converting your fan clutch upgrades it from a medium duty fan clutch to a heavy duty fan clutch. Our model is capable of handling a larger fan and will last longer than the competition.

Patent(s) Pending. See www.kit-masters.com for updated list of applicable issued and pending patents.
For installation assistance, contact Kit Masters at (800)-810-9110